

# Basler A500 Series

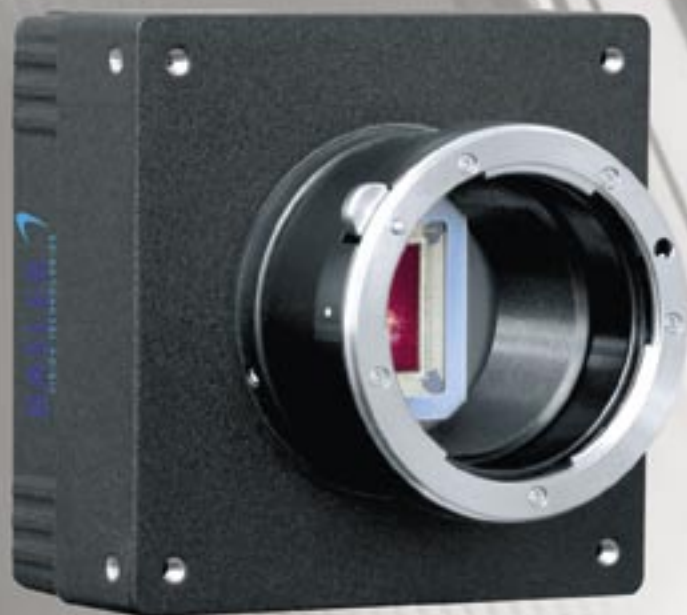

The A500 Area Scan Series

### Description

The A500 Series of high-performance, digital cameras is ideal for industrial users who require the exceptionally high frame rates offered by CMOS technology. The cameras can be triggered via an external sync signal or run in an internally controlled „free-run“ mode. A500 cameras operate with a single voltage power supply and have the advantages of the remarkably simple cabling requirements outlined in the Camera Link standard. A combination of features such as digital shift, test images, and indicator LEDs, ensure that these versatile cameras provide an exceptional price/performance ratio.

The A500 series cameras are ideal for applications like: Dynamic motion inspection, semiconductor and component inspection, manufacturing quality control, human motion analysis, digital archiving, and many other vision applications.



### Camera Link<sup>®</sup> Interface

Camera Link is a communication link for visual applications in the fields of science and industry.

Camera Link was founded in the year 2000 by Basler and other leading companies in the machine vision arena.

Camera Link enables a maximum data transmission rate of 680 MB per second depending on the configuration.

Frame grabbers which collect and evaluate the data are usually used to connect the camera and the PC via the Camera Link interface.

The most important benefits afforded by Camera Link are:

- Accepted communication standard for vision technologies (camera frame grabber)
- Simple and standardized cable concept
- Particular suitability for high data rates
- Standardized data protocol for several types of data transfer, for example single/dual tap, 8 bit, 10 bit, RGB, etc.
- Serial communication to the camera via the frame grabber communication port

The standard CameraLink interface used on the A500 family makes these cameras compatible with frame grabbers produced by many different vendors. These vendors include: Cognex, Matrox, National Instruments, Euresys, Matrix Vision, BitFlow, and Mikrotron. An overview showing more frame grabber vendors and frame grabbers compatible with A500 series cameras can be found on the Basler webpage at [www.basler-vc.com](http://www.basler-vc.com).

#### Your benefits include:

- Superior image quality improves your image processing results
- Compact size reduces the space needed in your installation
- 100% factory testing ensures consistent product quality
- LED indicators and test image generation capability reduce your integration time and aid troubleshooting
- Area of Interest (AOI) scanning allows higher frame rates
- Windows<sup>®</sup> setup tool lets you configure your camera with ease
- Electronic exposure time control provides maximum flexibility

# Specifications

Basler A500 Series	A501k/kc	A504k/kc
<b>Camera</b>		
Resolution	1280 x 1024	
Sensor Type	Progressive Scan CMOS	
Pixel Size (µm)	12.0 x 12.0	
Camera Link Clock	50 MHz	67 MHz
Frame Rate at Full Resolution	74 fps	500 fps
Mono/Color	Color or Mono	Color or Mono
Video Output Type	Camera Link (Base)*	Camera Link (Full)**
Video Output Format	2 taps, 8 bits each	10 taps, 8 bits each
Gain Control	0-12 dB	0-12 dB
Synchronization	Via external trigger or free run	
Exposure Control	Edge-controlled, level-controlled, or programmable	
<b>Mechanical / Electrical</b>		
Housing Size (L x W x H)	41.5 mm x 90 mm x 90 mm	
Weight	Max. 600 g	Max. 610 g
Power Requirements	12 VDC (±10%), max. 3.0 W	12 VDC (±10%), max. 6.0 W
Mount-Type	F-mount	
Conformity	CE, FCC	

Specifications are subject to change without prior notice

\* The output is RS-644 LVDS when this camera is used with an optional Basler Interface Converter (BIC)

\*\* The 10 tap, 8bit format is a proposed addition to the Camera Link standard

# Dimensions (in mm)

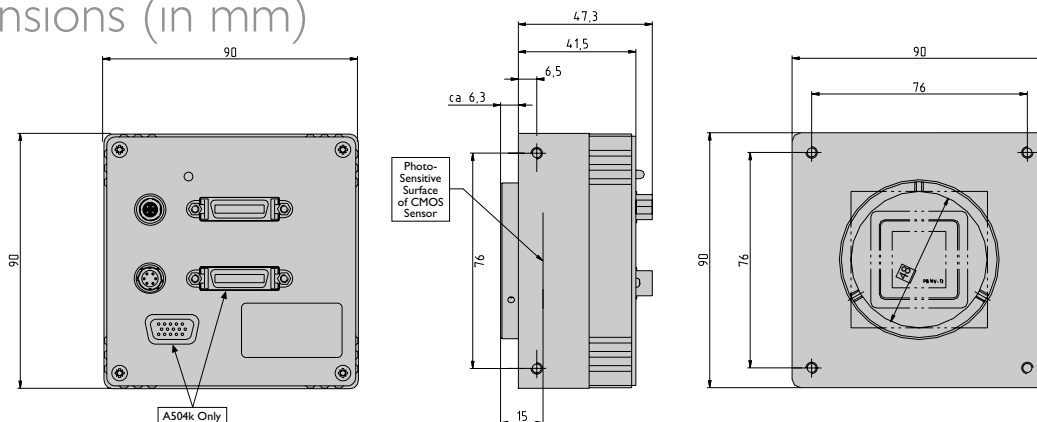

## What Makes Basler Camera Quality so Special?

To ensure consistently high product quality, we employ several quality inspection procedures during manufacturing. This list describes three of the most essential actions we take to meet your highest requirements.



- The back focal length on each camera is carefully measured and adjusted. This guarantees an optimum distance between the lens flange and the sensor and compliance to optics standards.
- Our advanced Camera Test Tool (CTT+), the first fully-automated inspection system for digital cameras, checks

all of the significant quality aspects of each camera we produce. The CTT+ is a unique combination of optics, hardware, and software that can be quickly and efficiently used to calibrate a camera and to measure its performance against a set of standards. For defined sets of conditions, an automated software program examines the camera's output, makes any calibration adjustments necessary, and compares the output to a strictly defined set of performance criteria.

- As a final check, our cameras must pass a stress test. Each camera is tested over the entire temperature range specified in our documentation. By doing this, we can identify and remove temperature sensitive weak spots in the camera. Thus, consistent image quality in conditions with quickly changing temperatures is guaranteed.



[www.basler-vc.com](http://www.basler-vc.com)

### Germany, Headquarters

Fon +49 4102 463 500  
 Fax +49 4102 463 599  
[vc.sales.europe@baslerweb.com](mailto:vc.sales.europe@baslerweb.com)

### USA

Fon +1 610 280 0171  
 Fax +1 610 280 7608  
[vc.sales.usa@baslerweb.com](mailto:vc.sales.usa@baslerweb.com)

### Singapore

Fon +65 6425 0472  
 Fax +65 6425 0473  
[vc.sales.asia@baslerweb.com](mailto:vc.sales.asia@baslerweb.com)